

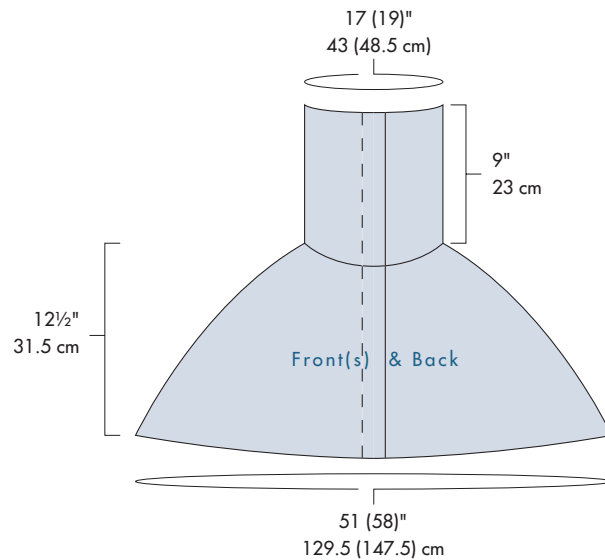

Right band: Work as for left band, but make 2 buttonholes, one even with Row 47 of chart, and the other one even with Row 71 of chart (both 3/3RC cable-crossing rows), as foll: (RS) Work 5 sts in patt, BO 2 sts, work in patt to end. On the next row, use the backward loop method (see Glossary, page 146) to CO 2 sts over the BO sts in the previous row to complete the buttonhole. Complete as for left band, ending with a WS row. Do not cut yarn.

Collar: With size 6 (4-mm) needle, work 9 sts of right band in established rib, ssk (see Glossary, page 149); with same yarn, cont across capelet sts as foll: p2tog, p1, work k2, p2 rib as established to last 3 sts, p2tog, p1; with same yarn, cont across left band as foll: k2tog, work to end in established rib—142 (158) sts. Cont even as established until piece measures 3½" (9 cm) from last buttonhole, ending with a WS row. **Next row:** (buttonhole row) Work 5 sts in patt, BO 2 sts, work in patt to end. On next row, CO 2 sts over the BO sts as before. Cont even as established until collar measures 9" (23 cm), ending with a WS row. BO all sts in rib patts.

Sew the bands to the front edges of the cape using mattress stitch. Sew buttons to left front, opposite buttonholes. Weave in loose ends. Block lightly.



Work large motifs at the wide base and small motifs at the top, where the cape tapers for the neck.